

# ENVIROFAN

Gold Line

160F-7

## Specifications:

Size: 56" (curved blades)  
Weight: 24 lbs.  
CFM: 34,500  
Area: 2,100  
RPM: 350  
Velocity: 650 ft./min.  
Amps: .64  
Volts: 120V, 60Hz

Safety Cable: 13"

Cord & Plug: 16" (from top of bell)

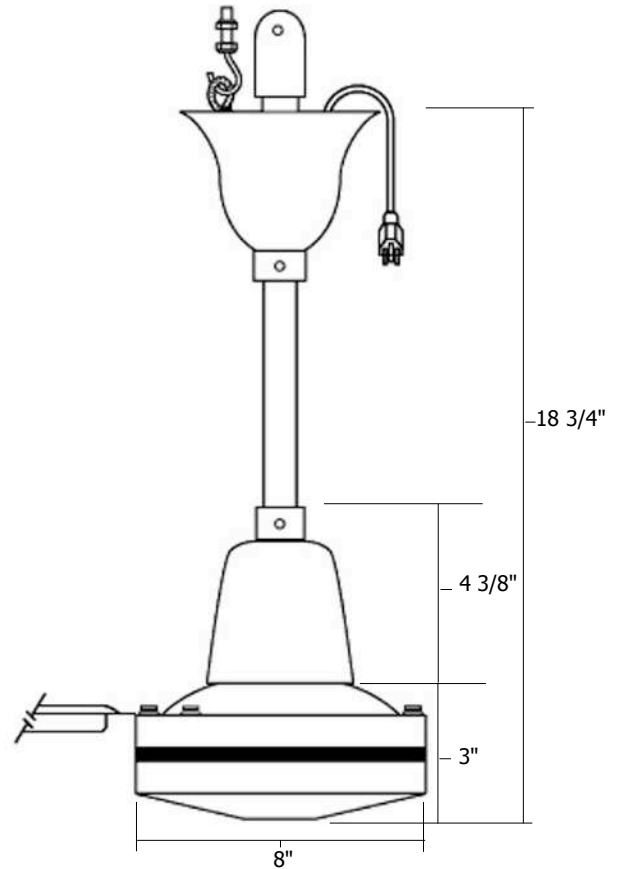
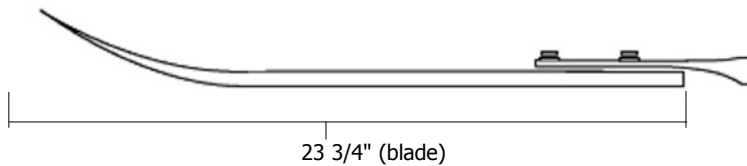

## Features:

Thermo Protected Motor  
Secondary Support Cable  
Cast Iron Motor Housing  
Aluminum Blades  
UL Listed - Meets all 507 standards  
5 year warranty  
10" Downrod (3/4" i.d.)



## Note:

To reduce risk of injury to persons, install fan so that blades are at least 10 feet above floor  
Technical specifications subject to change without notice

## Northwest Envirofan

A Division of Northwest Environmental Systems, Inc.

Envirofan Ceiling Fans • Protecto-Guard Ceiling Fan Guards • Fan Controls

800-236-7080

(920) 235-7808

FAX (920) 235-3049